



Installation Instructions

FLEX I/O ac Digital Output Modules

Cat. No. 1794-0A8, -0A8K, -0A8I, -0A16

(Modules with a K in the last position of the catalog number are conformally coated to meet noxious gas requirements of ISA/ANSI-71.040-1985 Class G3 Environment.)

Important User Information

Solid state equipment has operational characteristics differing from those of electromechanical equipment. *Safety Guidelines for the Application, Installation and Maintenance of Solid State Controls* (Publication SGI-1.1 available from your local Rockwell Automation sales office or online at <http://www.ab.com/manuals/gi>) describes some important differences between solid state equipment and hard-wired electromechanical devices. Because of this difference, and also because of the wide variety of uses for solid state equipment, all persons responsible for applying this equipment must satisfy themselves that each intended application of this equipment is acceptable.

In no event will Rockwell Automation, Inc. be responsible or liable for indirect or consequential damages resulting from the use or application of this equipment.

The examples and diagrams in this manual are included solely for illustrative purposes. Because of the many variables and requirements associated with any particular installation, Rockwell Automation, Inc. cannot assume responsibility or liability for actual use based on the examples and diagrams.

No patent liability is assumed by Rockwell Automation, Inc. with respect to use of information, circuits, equipment, or software described in this manual.

Reproduction of the contents of this manual, in whole or in part, without written permission of Rockwell Automation, Inc. is prohibited.

Throughout this manual we use notes to make you aware of safety considerations.

WARNING Identifies information about practices or circumstances that can cause an explosion in a hazardous environment, which may lead to personal injury or death, property damage, or economic loss.



IMPORTANT Identifies information that is critical for successful application and understanding of the product.

ATTENTION Identifies information about practices or circumstances that can lead to personal injury or death, property damage, or economic loss. Attentions help you:



- identify a hazard
- avoid a hazard
- recognize the consequence

WARNING When you insert or remove the module while backplane power is on, an electrical arc can occur. This could cause an explosion in hazardous location installations. Be sure that power is removed or the area is nonhazardous before proceeding.



WARNING If you connect or disconnect wiring while the field side power is on, an electrical arc can occur. This could cause an explosion in hazardous location installations. Be sure that power is removed or the area is nonhazardous before proceeding.



ATTENTION FLEX I/O is grounded through the DIN rail to chassis ground. Use zinc plated yellow-chromate steel DIN rail to assure proper grounding. The use of other DIN rail materials (e.g. aluminum, plastic, etc.) that can corrode, oxidize, or are poor conductors, can result in improper or intermittent grounding.



ATTENTION



Environment and Enclosure

This equipment is intended for use in a Pollution Degree 2 industrial environment, in overvoltage Category II applications (as defined in IEC publication 60664-1), at altitudes up to 2000 meters without derating.

This equipment is considered Group 1, Class A industrial equipment according to IEC/CISPR Publication 11. Without appropriate precautions, there may be potential difficulties ensuring electromagnetic compatibility in other environments due to conducted as well as radiated disturbance.

This equipment is supplied as "open type" equipment. It must be mounted within an enclosure that is suitably designed for those specific environmental conditions that will be present and appropriately designed to prevent personal injury resulting from accessibility to live parts. The interior of the enclosure must be accessible only by the use of a tool. Subsequent sections of this publication may contain additional information regarding specific enclosure type ratings that are required to comply with certain product safety certifications.

See NEMA Standards publication 250 and IEC publication 60529, as applicable, for explanations of the degrees of protection provided by different types of enclosure. Also, see the appropriate sections in this publication, as well as the Allen-Bradley publication 1770-4.1 ("Industrial Automation Wiring and Grounding Guidelines"), for additional installation requirements pertaining to this equipment.

ATTENTION



Preventing Electrostatic Discharge

This equipment is sensitive to electrostatic discharge, which can cause internal damage and affect normal operation. Follow these guidelines when you handle this equipment:

- Touch a grounded object to discharge potential static.
- Wear an approved grounding wriststrap.
- Do not touch connectors or pins on component boards.
- Do not touch circuit components inside the equipment.
- If available, use a static-safe workstation.

North American Hazardous Location Approval

The following output modules are North American Hazardous Location approved: 1794-0A8, -0A8K, -0A8I and -0A16.

The following information applies when operating this equipment in hazardous locations:	Informations sur l'utilisation de cet équipement en environnements dangereux :
Products marked "CL 1, DIV 2, GP A, B, C, D" are suitable for use in Class 1 Division 2 Groups A, B, C, D, Hazardous Locations and nonhazardous locations only. Each product is supplied with markings on the rating nameplate indicating the hazardous location temperature code. When combining products within a system, the most adverse temperature code (lowest "T" number) may be used to help determine the overall temperature code of the system. Combinations of equipment in your system are subject to investigation by the local Authority Having Jurisdiction at the time of installation.	Les produits marqués "CL 1, DIV 2, GP A, B, C, D" ne conviennent qu'à une utilisation en environnements de Classe 1 Division 2 Groupes A, B, C, D dangereux et non dangereux. Chaque produit est livré avec des marquages sur sa plaque d'identification qui indiquent le code de température pour les environnements dangereux. Lorsque plusieurs produits sont combinés dans un système, le code de température le plus défavorable (code de température le plus faible) peut être utilisé pour déterminer le code de température global du système. Les combinaisons d'équipements dans le système sont sujettes à inspection par les autorités locales qualifiées au moment de l'installation.

WARNING	EXPLOSION HAZARD	AVERTISSEMENT	RISQUE D'EXPLOSION
	<ul style="list-style-type: none"> • Do not disconnect equipment unless power has been removed or the area is known to be nonhazardous. • Do not disconnect connections to this equipment unless power has been removed or the area is known to be nonhazardous. Secure any external connections that mate to this equipment by using screws, sliding latches, threaded connectors, or other means provided with this product. • Substitution of components may impair suitability for Class 1, Division 2. • If this product contains batteries, they must only be changed in an area known to be nonhazardous. 		<ul style="list-style-type: none"> • Couper le courant ou s'assurer que l'environnement est classé non dangereux avant de débrancher l'équipement. • Couper le courant ou s'assurer que l'environnement est classé non dangereux avant de débrancher les connecteurs. Fixer tous les connecteurs externes reliés à cet équipement à l'aide de vis, loquets coulissants, connecteurs filetés ou autres moyens fournis avec ce produit. • La substitution de composants peut rendre cet équipement inadapté à une utilisation en environnement de Classe 1, Division 2. • S'assurer que l'environnement est classé non dangereux avant de changer les piles.

European Hazardous Location Approval

The following module is European Zone 2 approved: 1794-OA8K.

European Zone 2 Certification (The following applies when the product bears the EEx Marking)

This equipment is intended for use in potentially explosive atmospheres as defined by European Union Directive 94/9/EC.

The LCIE (Laboratoire Central des Industries Electriques) certifies that this equipment has been found to comply with the Essential Health and Safety Requirements relating to the design and construction of Category 3 equipment intended for use in potentially explosive atmospheres, given in Annex II to this Directive. The examination and test results are recorded in confidential report No. 28 682 010.

Compliance with the Essential Health and Safety Requirements has been assured by compliance with EN 50021.

IMPORTANT

Observe the following additional Zone 2 certification requirements.

- This equipment is not resistant to sunlight or other sources of UV radiation.
- The secondary of a current transformer shall not be open-circuited when applied in Class I, Zone 2 environments.
- Equipment of lesser Enclosure Type Rating must be installed in an enclosure providing at least IP54 protection when applied in Class I, Zone 2 environments.
- This equipment shall be used within its specified ratings defined by Allen-Bradley.
- Provision shall be made to prevent the rated voltage from being exceeded by transient disturbances of more than 40% when applied in Class I, Zone 2 environments

Installing Your ac Digital Output Module

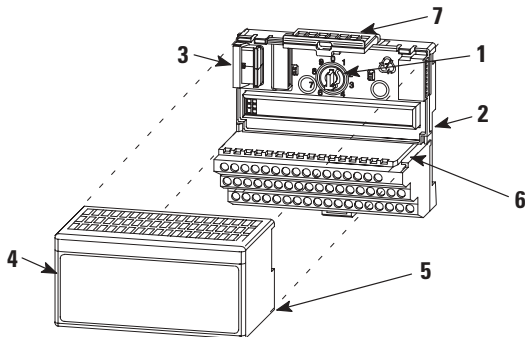

The module mounts on a 1794 terminal base.

ATTENTION



During mounting of all devices, be sure that all debris (metal chips, wire strands, etc.) is kept from falling into the module. Debris that falls into the module could cause damage on power up.

1. Rotate the keyswitch (1) on the terminal base (2) clockwise to position 8 as required for this type of module.
2. Make certain the flexbus connector (3) is pushed all the way to the left to connect with the neighboring terminal base/adaptor. **You cannot install the module unless the connector is fully extended.**
3. Make sure the pins on the bottom of the module are straight so they will align properly with the connector in the terminal base.

WARNING



If you remove or insert the module while the backplane power is on, an electrical arc can occur. This could cause an explosion in hazardous location installations. Be sure that power is removed or the area is nonhazardous before proceeding.

4. Position the module (4) with its alignment bar (5) aligned with the groove (6) on the terminal base.
5. Press firmly and evenly to seat the module in the terminal base unit. The module is seated when the latching mechanism (7) is locked into the module.

Connecting Wiring for the 1794-OA8 and -OA8K

1. **For 1794-TB2, -TB3, or -TB3S** - Connect individual output wiring to even numbered terminals on the 0-15 row (A) as indicated in the table below.
For 1794-TBN or -TBNF - Connect individual output wiring to even numbered terminals on the 16-33 row (B) as indicated in the table below.
2. **For 1794-TB2, -TB3, or -TB3S** - Connect the associated V ac common (L2) lead of the output device to the corresponding odd numbered terminal on the 0-15 row (A) for each output as indicated in the table below; or to the corresponding terminal on the 16-33 row (B). (The V ac common (L2) terminals of row (B) and the odd numbered terminals of row (A) are internally connected together.)
For 1794-TBN or -TBNF - Connect the associated V ac common (L2) lead of the output device to the corresponding odd numbered terminal on the 34-51 row (C) for each output as indicated in the table below. (The odd numbered terminals of row (C) are internally connected together to V ac L2 common.)
3. Connect V ac power L1 to terminal 34 on the 34-51 row (C).
4. Connect V ac common L2 to terminal 16 on the 16-33 row (B).
5. If daisy chaining V ac power (L1) to the next terminal base, connect a jumper from terminal 51 (V ac L1) on this base unit to terminal 34 on the next base unit.
6. If continuing V ac common (L2) to the next base unit, connect a jumper from terminal 33 (V common L2) on this base unit to terminal 16 on the next base unit.

Note: Total current draw through terminal base connection is limited to 10A. Separate power connections to each terminal base may be necessary.

Wiring Connections for the 1794-OA8 and -OA8K

Output ¹	1794-TB2, -TB3, -TB3S		1794-TBN, -TBNF	
	Output Terminal	Common Terminal (L2)	Output Terminal	Common Terminal (L2)
0	A-0	A-1 ¹ /B-17	B-0	C-1 ²
1	A-2	A-3 ¹ /B-19	B-2	C-3 ²
2	A-4	A-5 ¹ /B-21	B-4	C-5 ²
3	A-6	A-7 ¹ /B-23	B-6	C-7 ²
4	A-8	A-9 ¹ /B-25	B-8	C-9 ²
5	A-10	A-11 ¹ /B-27	B-10	C-11 ²
6	A-12	A-13 ¹ /B-29	B-12	C-13 ²
7	A-14	A-15 ¹ /B-31	B-14	C-15 ²

A = Output terminals (Even numbered terminals 0 thru 14)
 B = Common terminals
 C = Power terminals (C-34 and C-51 on -TB2; C-34 thru C-51 on -TB3 and -TB3S)

B = Even numbered output terminals 0-14, ac common terminals 16 and 33
 C = Power terminals C-34 and C-51, and odd numbered output terminals 1 thru 15

1 A-1, 3, 5, 7, 9, 11, 13 and 15 on the 1794-TB2, -TB3 and -TB3S are internally connected in the module to 120V ac common (L2).
 2 C-1, 3, 5, 7, 9, 11, 13 and 15 on the 1794-TBN and -TBNF are internally connected in the module to 120V ac common (L2).

1794-TB2, -TB3 and -TB3S Terminal Base Wiring for the 1794-OA8

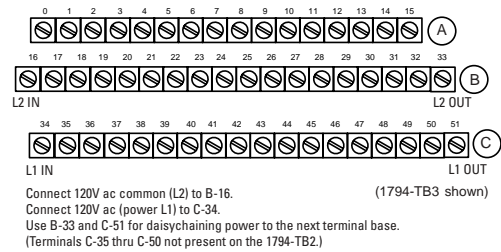

1794-TBN and -TBNF Terminal Base Wiring for the 1794-OA8

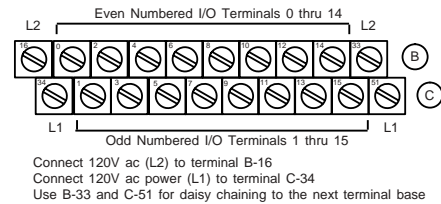

Connecting Wiring for the 1794-OA8I

- For 1794-TB2, -TB3, or -TB3S - Connect individual output wiring to the even numbered terminals on the 0-15 row (A).
 For 1794-TBN or -TBNF - Connect individual output wiring to the even numbered terminals on the 16-33 row (B)
- For 1794-TB2, -TB3, or -TB3S - Connect the associated V ac power lead (L1) to the corresponding odd numbered terminal on the 0-15 row (A) for each output as indicated in the table below.
 For 1794-TBN or -TBNF - Connect the associated V ac power (L1) lead to the odd numbered terminals on row (C)

ATTENTION Individual isolated 120V ac common (L2) leads must be run externally to each output device.



Wiring Connections for the 1794-OA8I

Output ¹	1794-TB2, -TB3, -TB3S		1794-TBN, -TBNF	
	Output Terminal	120V ac Supply	Output Terminal	120V ac Supply
0	A-0	A-1 ¹	B-0	C-1 ²
1	A-2	A-3 ¹	B-2	C-3 ²
2	A-4	A-5 ¹	B-4	C-5 ²
3	A-6	A-7 ¹	B-6	C-7 ²
4	A-8	A-9 ¹	B-8	C-9 ²
5	A-10	A-11	B-10	C-11 ²
6	A-12	A-13 ¹	B-12	C-13 ²
7	A-14	A-15 ¹	B-14	C-15 ²

1 A = Even numbered terminals 0 thru 14 for customer connections; corresponding odd numbered 120V ac supply L1 terminals 1 thru 15 for customer connections from isolated power supply.
 2 B = Even numbered terminals 0 thru 14 for customer connections; C = Odd numbered 120V ac supply L1 terminals 1 thru 15 for customer connections from isolated power supply.

1794-TB2, -TB3 and -TB3S Terminal Base Wiring for the 1794-OA8I

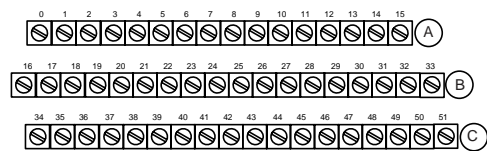

Connect outputs to even numbered terminals on row (A) (1794-TB3 shown)
 Connect isolated 120V ac (L1) to odd numbered terminals on row (A)
 Individual isolated 120V ac common (L2) must be run externally to each of the output devices
 (Terminals C-35 thru C-50 are not available on the 1794-TB2.)

1794-TBN and -TBNF Terminal Base Wiring for the 1794-OA8I

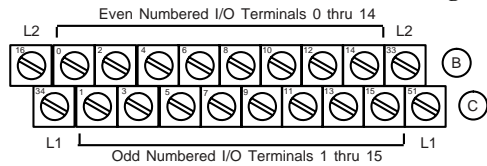

Connect outputs to even numbered terminals on row (B).
 Connect isolated 120V ac (L1) to odd numbered terminals on row (C).
 Individual isolated 120V ac common (L2) must be run externally to each of the output devices.

Connecting Wiring for the 1794-OA16

- For 1794-TB2, -TB3, or -TB3S - Connect individual output wiring to numbered terminals on the 0-15 row (A) as indicated in the table below.
 For 1794-TBN - Connect individual output wiring to terminals 0 thru 15 on rows B and C.
- For 1794-TB2, -TB3 or -TB3S - Connect the associated V ac common (L2) lead of the output device to the corresponding numbered terminal on the 16-33 row (B) for each output as indicated in the table below. (The V ac common terminals of row (B) are internally connected together.)
 For 1794-TBN - Auxiliary terminal blocks are required to connect the associated L2 common for each channel. Connect the L2 side of the load together and then connect to L2 on the power supply.
- Connect 120V ac power L1 to terminal 34 on the 34-51 row (C).
- Connect 120V ac common L2 to terminal 16 on the 16-33 row (B).
- If daisy chaining power to the next terminal base, connect a jumper from terminal 51 (120V ac L1) on this base unit to terminal 34 on the next base unit.
- If continuing 120V ac common (L2) to the next base unit, connect a jumper from terminal 33 (120V ac common L2) on this base unit to terminal 16 on the next base unit.

Note: Total current draw through terminal base connection is limited to 10A. Separate power connections to each terminal base may be necessary.

Wiring Connections for the 1794-OA16

Output Channel	1794-TB2, -TB3, -TB3S		1794-TBN
	Output Terminal	120V ac Common (L2)	Output Terminal ¹
0	A-0	B-17	B-0
1	A-1	B-18	C-1
2	A-2	B-19	B-2
3	A-3	B-20	C-3
4	A-4	B-21	B-4
5	A-5	B-22	C-5
6	A-6	B-23	B-6
7	A-7	B-24	C-7
8	A-8	B-25	B-8
9	A-9	B-26	C-9
10	A-10	B-27	B-10
11	A-11	B-28	C-11
12	A-12	B-29	B-12
13	A-13	B-30	C-13
14	A-14	B-31	B-14
15	A-15	B-32	C-15

120V ac L1 power	Connect V ac L1 to C-34. 1794-TB3, -TB3S - Power terminals C-34 thru C-51 are internally connected together. 1794-TB2 and -TBN - C-34 and C-51 are internally connected together.
120V ac L2 common	Connect 120V ac common L2 to terminal B-16. 1794-TB3, -TB3S - 120V ac common L2 terminals B-16 thru B-33 are internally connected together. 1794-TB2, -TBN - 120V ac common L2 terminals B-16 and B-33 internally connected together.

¹ **Note:** Auxiliary terminal blocks are required to connect the associated L2 common for each channel when using a 1794-TBN terminal base with the 1794-OA16.

1794-TB2, -TB3 and -TB3S Terminal Base Wiring for the 1794-OA16

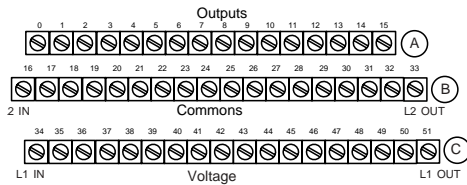

Connect 120V ac common L2 to terminal B-16. (1794-TB3 shown)
 Connect 120V ac power L1 to terminal C-34.
 (Use B-33 and C-51 for daisy-chaining power to the next terminal base unit.)
 Terminals C-35 thru C-50 are not present on the 1794-TB2.)

1794-TBN Terminal Base Wiring for the 1794-OA16

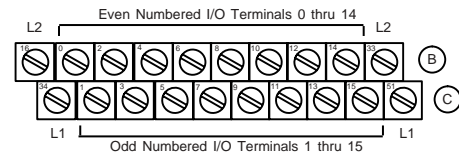

Connect 120V ac (L2) to terminal B-16
 Connect 120V ac power (L1) to terminal C-34
 Use B-33 and C-51 for daisy chaining to the next terminal base

Configuring Your ac Output Module

Image Table Memory Map for the 1794-OA8, -OA8K and -OA8I.

Dec.	15	14	13	12	11	10	9	8	7	6	5	4	3	2	1	0
Oct.	17	16	15	14	13	12	11	10	7	6	5	4	3	2	1	0
Read	Not used - set to 0															
Write	Not used - set to 0															
	0	0	0	0	0	0	0	0	0	0	0	0	0	0	0	0
	7	6	5	4	3	2	1	0								

Where 0 = Output number

Image Table Memory Map for the 1794-OA16

Dec.	15	14	13	12	11	10	9	8	7	6	5	4	3	2	1	0
Oct.	17	16	15	14	13	12	11	10	7	6	5	4	3	2	1	0
Read	Not used - set to 0															
Write	0	0	0	0	0	0	0	0	0	0	0	0	0	0	0	0
	15	14	13	12	11	10	9	8	7	6	5	4	3	2	1	0

Where 0 = Output number

Specifications

Specifications -	1794-OA8, -OA8K	1794-OA8I
Number of Outputs	8, (1 group of 8), nonisolated	8, isolated
Module Location	Cat. No. 1794-TB2, -TB3, -TB3S, -TBN and -TBNF	
Output Voltage Range	85V ac minimum 120V ac nominal 132V ac maximum	
Output Current Rating	4.0A (8 outputs @ 500mA)	
ON-state Current	5.0mA per output minimum 500mA per output maximum @ 55°C (sufficient to operate an Allen-Bradley Bulletin 500 NEMA size 3 motor starter) 750mA per output maximum @ 35°C 1.0A on 4 nonadjacent outputs, 500mA on the remaining 4 outputs @ 30°C NOTE: Below 50mA the voltage drop across the module will be higher and the voltage waveform may have some small oscillation (less than 5V).	
Maximum ON-state Voltage Drop	1.0V @ 0.5A	
Maximum OFF-state Leakage Current	2.25mA	
Surge Current	7A for 40ms, repeatable every 8 seconds	
Output Signal Delay ¹	Off to On On to Off 1/2 cycle maximum 1/2 cycle maximum	
Isolation Voltage	Tested at 2150V dc for 1s between user and system No isolation between individual channels; no isolation between customer power and output channels	Tested at 2150V dc for 1s between all channels and system; 2150V dc for 1s between individual channels
Power Dissipation	4.1W maximum @ 0.5A 6.3W maximum @ 0.75A 6.3W maximum @ 1.0A	
Thermal Dissipation	14.0 BTU/hr @ 0.5A 21.2 BTU/hr @ 0.75A 21.4 BTU/hr @ 1.0A	
Flexbus Current	80mA @5V dc	
Fusing ²	1.6A, 250V ac slow-blow, Littelfuse 23901.6; San-O SD6-1.6 (1.6A fuses come preinstalled in 1794-TBNF terminal base units.)	

Specifications -	1794-OA16
Number of Outputs	16, nonisolated
Module Location	Cat. No. 1794-TB2, -TB3, -TB3S and -TBN ³
Mounting	See derating curve below.
Output Voltage Range	74V ac minimum, 47-63Hz 120V ac nominal, 47-63Hz 132V ac maximum, 47-63Hz
Output Current Rating	4.0A (16 outputs @ 250mA) Attention: If using 0.5A outputs, alternate wiring so that no two 0.5A outputs are next to each other.
ON-state Current	5.0mA per output minimum 500mA per output maximum @ 55°C NOTE: Below 50mA the voltage drop across the module will be higher and the voltage waveform may have some small oscillation (less than 5V).
Maximum ON-state Voltage Drop	1.5V @ 0.5A
Maximum OFF-state Leakage Current	2.25mA
Surge Current	7A for 40ms, repeatable every 8 seconds

Output Signal Delay ¹ Off to On On to Off	1/2 cycle maximum 1/2 cycle maximum
Isolation Voltage	Tested at 2150V dc for 1s between user and system No isolation between individual channels; no isolation between customer power and output channels
Power Dissipation	4.7W maximum @ 0.5A
Thermal Dissipation	16.1 BTU/hr @ 0.5A
Flexbus Current	80mA @5V dc
Fusing ²	2.5A, 150V ac normal blow, MQ2

General Specifications

Terminal Base Screw Torque	7 pound-inches (0.8Nm) 9 pound-inches (1.0Nm) for 1794-TBN , -TBNF
Dimensions (with module installed)	3.7H x 3.7W x 2.7D inches 94H x 94W x 69D mm
Indicators (field side indication, logic driven)	1794-OA8, -OA8K - 8 yellow status indicators 1794-OA8I - 8 yellow status indicators 1794-OA16 - 16 yellow status indicators
External ac power Supply voltage Voltage range	120V ac nominal 1794-OA8, -OA8K, -OA8I - 85 to 132V ac, 47-63Hz 1794-OA16 - 74 to 132V ac, 47-63Hz
Keyswitch Position	8
Environmental Conditions	
Operating Temperature	IEC 60068-2-1 (Test Ad, Operating Cold), IEC 60068-2-2 (Test Bd, Operating Dry Heat), IEC 60068-2-14 (Test Nb, Operating Thermal Shock): 0 to 55°C (32 to 131°F)
Storage Temperature	IEC 60068-2-1 (Test Ab, Un-packaged Non-operating Cold), IEC 60068-2-2 (Test Bb, Un-packaged Non-operating Dry Heat), IEC 60068-2-14 (Test Na, Un-packaged Non-operating Thermal Shock): -40 to 85°C (-40 to 185°F)
Relative Humidity	IEC 60068-2-30 (Test Db, Un-packaged Non-operating Damp Heat): 5 to 95% non-condensing
Vibration	IEC60068-2-6 (Test Fc, Operating): 5g @ 10-500Hz
Shock	IEC60068-2-27 (Test Ea, Unpackaged shock): Operating 30g Non-operating 50g
Emissions	CISPR 11: Group 1, Class A (with appropriate enclosure)
ESD Immunity	IEC 61000-4-2: 4kV contact discharges 8kV air discharges
Radiated RF Immunity	IEC 61000-4-3: 10V/m with 1kHz sine-wave 80%AM from 30MHz to 1000MHz 10V/m with 200Hz 50% Pulse 100% AM at 900Hz
EFT/B Immunity	IEC 61000-4-4: ±2kV at 5kHz on signal ports ±2kV at 5kHz on power ports
Surge Transient Immunity	IEC 61000-4-5: ±1kV line-line(DM) and ±2kV line-earth(CM) on signal ports ±1kV line-line(DM) and ±2kV line-earth(CM) on power ports
Conducted RF Immunity	IEC 61000-4-6: 10Vrms with 1kHz sine-wave 80%AM from 150kHz to 80MHz
Enclosure Type Rating	None (open-style)

Conductors	Wire Size	22-12 AWG (0.34mm ² -2.5mm ²) stranded copper wire rated at 75°C or higher 3/64 inch (1.2mm) insulation maximum
	Category ⁴	2
Certifications (when product is marked) ⁵		UL UL Listed Industrial Control Equipment UL UL Listed Industrial Control Equipment, certified for US and Canada UL UL Listed for Class I, Division 2, Groups A, B, C and D Hazardous locations certified for US and Canada CSA CSA certified for Class I, Division 2, Groups A, B, C and D Hazardous locations EEx⁵ European Union 94/9/EEC ATEX Directive, compliant with: EN 50021: Potentially Explosive Atmospheres, Protection "n" (European Zone 2) - (1794-OA8K only) CE⁵ European Union 89/336/EEC EMC Directive, compliant with: EN 50082-2: Industrial Immunity EN 61000-6-2: Industrial Immunity (all) EN 61000-6-4: Industrial Emissions EN 61326: Meas./Control/Lab., Industrial Requirements European Union 73/23/EEC LVD Directive, compliant with: EN 61131-2: Programmable Controllers C-Tick⁵ - Australian Radiocommunications Act compliant with AS/NZS CISPR 11, Industrial Emissions

- 1 Output signal delay is the time from receipt of an output on or off command to the output actually turning on or off.
- 2 Module outputs are not fused. Fusing is recommended. If fusing is desired, you must supply external fusing or use the 1794-TBNF terminal base, if recommended.
- 3 **NOTE:** Auxiliary terminal blocks are required to connect the associated 120V ac common for each channel when using the 1794-TBN terminal base with the 1794-OA16.
- 4 You use this category information for planning conductor routing as described in Allen-Bradley publication 1770-4.1, Industrial Automation Wiring and Grounding Guidelines.
- 5 For the latest up-to-date information, see the Product Certification link at www.ab.com for Declarations of Conformity, Certificates and other certification details. For notification of any additional release notes, refer to www.ab.com/manuals/.

Derating Curve for the 1794-OA16

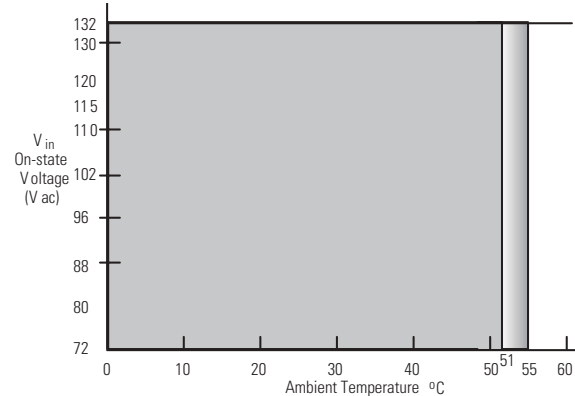

The area within the curve represents the safe operating range for the module under various conditions of user supplied 120V ac supply voltages and ambient temperatures.

- = Normal mounting safe operating range. Includes
- = Other mounting positions (including inverted horizontal, vertical) safe operating range

Mounting	Temperature (max.)
Normal horizontal	55°C
Other mounting positions (including inverted horizontal, vertical)	51°C

www.rockwellautomation.com

Corporate Headquarters

Rockwell Automation, 777 East Wisconsin Avenue, Suite 1400, Milwaukee, WI, 53202-5302 USA, Tel: (1) 414.212.5200, Fax: (1) 414.212.5201

Headquarters for Allen-Bradley Products, Rockwell Software Products and Global Manufacturing Solutions

Americas: Rockwell Automation, 1201 South Second Street, Milwaukee, WI 53204-2496 USA, Tel: (1) 414.382.2000, Fax: (1) 414.382.4444

Europe: Rockwell Automation SA/NV, Vorstlaan/Boulevard du Souverain 36-BP 3A/B, 1170 Brussels, Belgium, Tel: (32) 2 663 0600, Fax: (32) 2 663 0640

Asia Pacific: Rockwell Automation, 27/F Citicorp Centre, 18 Whitfield Road, Causeway Bay, Hong Kong, Tel: (852) 2887 4788, Fax: (852) 2508 1846

Headquarters for Dodge and Reliance Electric Products

Americas: Rockwell Automation, 6040 Ponders Court, Greenville, SC 29615-4617 USA, Tel: (1) 864.297.4800, Fax: (1) 864.281.2433

Europe: Rockwell Automation, Brühlstraße 22, D-74834 Elztal-Dallau, Germany, Tel: (49) 6261 9410, Fax: (49) 6261 17741

Asia Pacific: Rockwell Automation, 55 Newton Road, #11-01/02 Revenue House, Singapore 307987, Tel: (65) 351 6723, Fax: (65) 355 1733

Publication 1794-IN103A-EN-P - June 2004

Supersedes Publication 1794-5.10 - February 1999, 179405.56 - April 1998, 1794-5.6 - April 1999

PN 957824-03

Copyright © 2004 Rockwell Automation, Inc. All rights reserved. Printed in the U.S.A.